

목 록

lsv120ngl_datasheet.....	1
lsv120ngl_flyer.....	2
lsv120ngl_dimension.....	6

Laser interferometric Vibrometer LSV-NG Series

System parameter	LSV 120 NG	LSV 120 NG/L	LSV 2500 NG
Measurable object frequency	0...5 MHz		
Amplitude measurement range (depending on surface)	≤±20 mm		
Resolution	5 µm		
Surface roughness	arbitrary		
Maximum displacement speed	3 m/s		
Working distance from sensor head	30...70, 240, 480 mm (fixed customized distance)	30...70, 240, 480 mm (changeable by customer)	240...2500 mm (continuously selectable)
Coherence maxima	-		240 mm + n·240 mm, n=0,1,2...
Wavelength	632.8 nm		
Frequency stability of HeNe laser (after warm-up time)	≤3·10 ⁻⁷		
Warm-up time of HeNe laser	approx. 10 min		
Operating temperature range	15...30°C		
Geometric Data			
Dimensions (L x W x H):			
Sensor head with adjustable mount	[133 x 91 x 54] mm	[147 x 96 x 60] mm	[209 x 96 x 58] mm
Electronic evaluation and supply unit EU (standard)		[450 x 400 x 150] mm	
Electronic evaluation and supply unit EU (compact)		[250 x 400 x 150] mm	
Mass:			
Sensor head with adjustable mount	660 g	700 g	800 g
Electronic evaluation and supply unit EU (standard)		ca. 8 kg	
Electronic evaluation and supply unit EU (compact)		ca. 5.7 kg	
Electrical Data			
Interfaces Standard	RS232C, USB		
other interfaces on request (/R)			
Cable length between sensor head and electronics unit	3 m, optionally up to 10 m		
Power supply	100...240 VAC / 47...63 Hz		
Laser safety class according to EN 60825-1:2014 and ANSI Z136.1 (CDRH)	2M II		

07/2020 · Subject to change.



LSV-NG

Product information

High-precision, non-contact vibration and length measurement on surfaces of any roughness

Laser interferometric vibrometer

LSV-NG

Many fields of application in industry and research require high-precision vibration measurements on various surfaces. Fast setup and uncomplicated adjustment as well as a robust design are particularly important.

Our laser-interferometric vibrometers measure the temporal position change of an object very precisely and contactless. The surface of the moving object may have any roughness. Mechanical oscillations with amplitudes up to $\pm 20 \mu\text{m}$ can be measured in the range of 0 to 5 MHz with a resolution in the subnanometer range.

The measuring system LSV 120 NG works with a fixed, selectable focal length. By means of a lens attachment, the model LSV 2500 NG has a continuously adjustable variable focal length.

The design of the vibrometer is both compact and robust, its housing is splash-proof and the fiber cables can be sheathed. Various modules are available for data evaluation and output. This allows the measuring system to be adapted to special tasks and customer requirements.

With the aid of a tripod the sensor head can be aligned very quickly and comfortably. A reflector is not required.



0–5 MHz

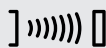

max. 3 m/s



5 μm

MEASURING PRINCIPLE

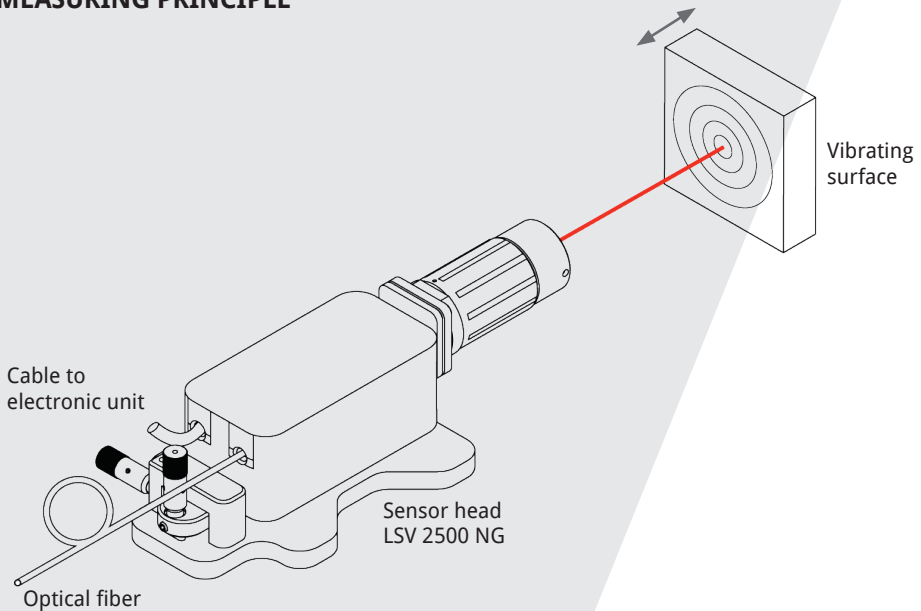

Fast and reliable
vibration measurement
on various surfaces

Further possible applications:

- Determination of vibration spectra
- Determination of vibration modes by point-by-point scanning of the surface (hardware extension required)
- Determination of resonant frequencies on micro-objects and macroscopic components
- Multi-coordinate measurements with multiple systems
- High-precision length measurements

Ideal for

- Quality assurance
- Development
- Science and research
- OEM applications

PRECISION & QUALITY
MADE IN GERMANY

For customer-specific versions, OEM applications or integration in special measurement stations, please contact us.

We will be happy to personally assist you in finding solutions to your measuring tasks.

SIOS Meßtechnik GmbH
Am Vogelherd 46
98693 Ilmenau / Germany

phone +49 (0) 3677 64 47-0
e-mail contact@sios.de

www.sios-precision.com

LSV 120 NG/L (A037448)

with adjustable mount & exchangeable lens attachment

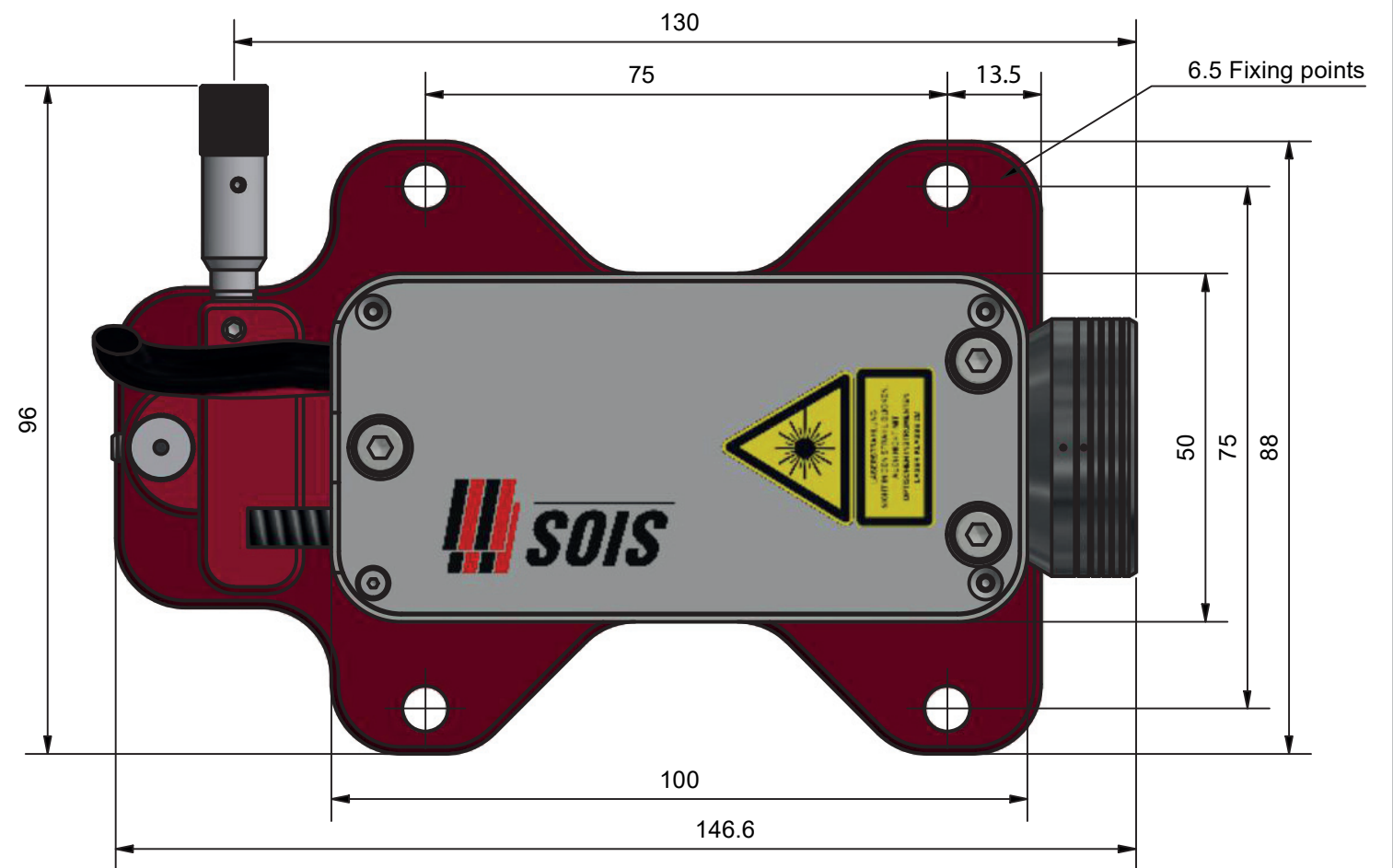
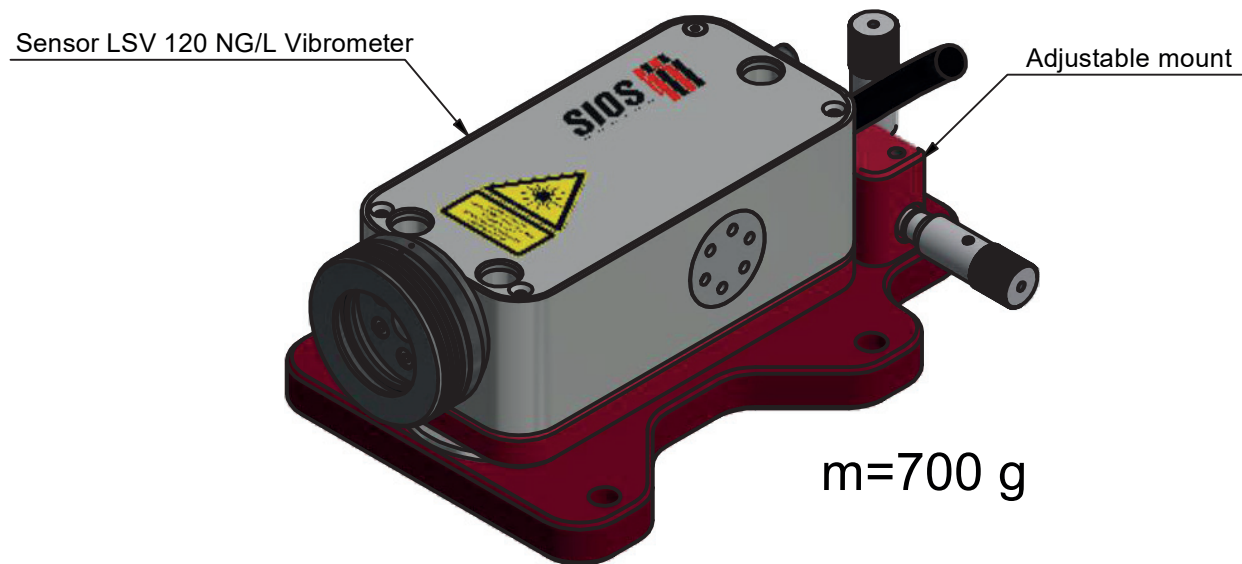
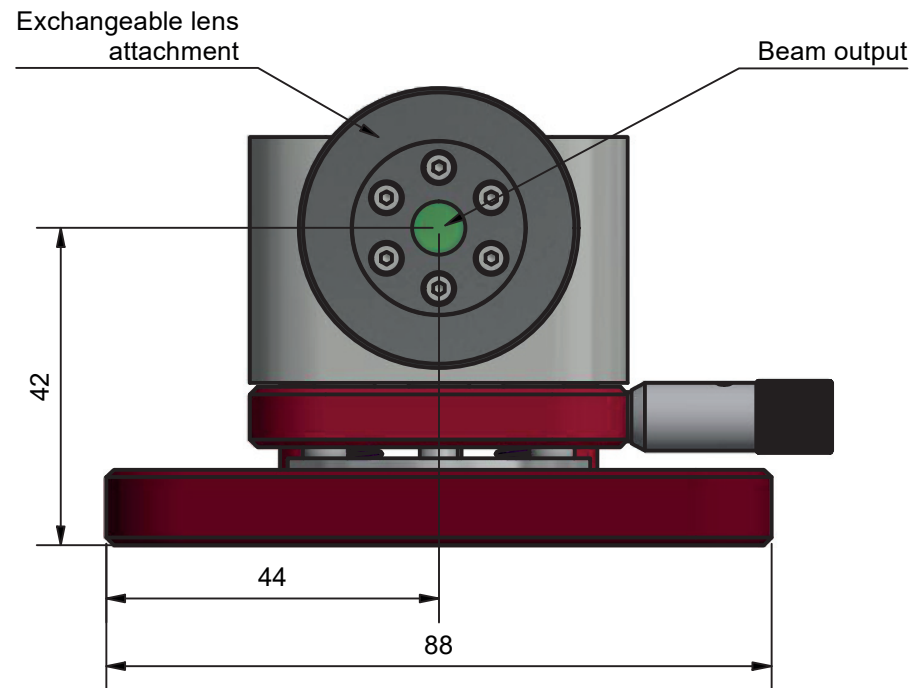

all dimensions in mm

SIOS Meßtechnik GmbH

Am Vogelherd 46 • 98693 Ilmenau/Germany • phone: +49 (0) 3677 64 47-0 • e-mail: contact@sios.de • www.sios-precision.com

SIOS
Meßtechnik GmbH